



Test Report: DAP-04

DALI-PWM Signal Converter

■ DESIGN VERIFY TEST

Output Function Test

Input Function Test

Control Function Test

DESIGN VERIFY TEST

OUTPUT FUNCTION TEST

NO	TEST ITEM	SPECIFICATION	TEST CONDITION	RESULT	VERDICT
1	NUMBER OF OUTPUT CHANNEL	4	I/P:230VAC O/P:NO LOAD Ta:25°C	4 CHANNELS	P
2	OUTPUT SIGNAL (Typ)	PWM 1KHZ ±1%	I/P: 230VAC O/P:FULL LOAD Ta:25°C	994.8 Hz	P
3	OUTPUT PWM LOGIC	PWM active High / Low selection. Short : Active High. Open : Active Low. Factory setting is Active High.	I/P: 230V O/P: 1%~100LOAD Ta:25°C	ACTIVE HIGH : SHORT ACTIVE LOW : OPEN	P
4	DIMMING RANGE	1%~100%	I/P:230VAC O/P: 1%~100LOAD Ta:25°C	TEST : OK	P

INPUT FUNCTION TEST

NO	TEST ITEM	SPECIFICATION	TEST CONDITION	RESULT	VERDICT
1	INPUT VOLTAGE RANGE	90VAC~305VAC	I/P:TESTING O/P:FULL LOAD Ta:25°C	80 V~ 305V	P
2	INPUT FREQUENCY RANGE	47HZ ~63 HZ NO DAMAGE OSC	I/P:90 VAC ~305 VAC O/P:FULL~MIN LOAD Ta:25°C	TEST: PASS	P
3	AC CURRENT(Typ)	277V/0.1A 230V/0.1 A 115V/0.1 A	I/P: 277VAC/230VAC/115VAC O/P:FULL LOAD Ta:25°C	I=0.013 A/ 277VAC I=0.012 A/ 230VAC I=0.013 A/ 115VAC	P
4	POWER CONSUMPTION(TYP)	0.5W	I/P:230 VAC O/P:FULL LOAD Ta:25°C	0.48 W	P
5	INPUT SIGNAL	DALI or PUSH DIM	I/P: 230 VAC O/P:FULL LOAD Ta:25°C	TEST : OK	P
6	NO LOAD POWER CONSUMPTION	<0.5W	I/P: 230 VAC I/P: 115 VAC O/P:NO LOAD Ta:25°C	0.45 W /230V 0.37W /115V	P
7	INRUSH CURRENT	15A/230VAC ($t_{width}=500\mu s$ measured at 50% I_{peak})	I/P: 230 VAC O/P:FULL LOAD Ta:25°C	12.9A/230V T50=490us	P
8	LEAKAGE CURRENT	< 0.5mA	I/P : 240 VAC O/P : Min LOAD Ta : 25°C	L-FG : 0.002mA N-FG : 0.002mA	P

CONTROL FUNCTION TEST

NO	TEST ITEM	SPECIFICATION	TEST CONDITION	RESULT	VERDICT
1	REALY SWITCH	240VAC / 8A, ON / OFF control refer to DIM1	I/P: 240VAC O/P: FULL LOAD Ta: 25°C	Relay contact rating(max.) : 240VAC / 8A resistive "Short" when DIM1 output duty cycle >0 ; "Open" when DIM1 output duty cycle=0	P
2	DALI DIMMING SOLUTION	DAP-04 with MEAN WELL's LED power supply	<p>Up to 4 channels</p>	<p>※Note: Choose a suitable cable for connecting the DAP-04 and DALI controller and make sure the maximum voltage drop between these two units should not be higher than 2V. (Maximum cable length for 1.5mm² cables is 300m.)</p>	P
3	PUSH DIMMING SOLUTION	DAP-04 with MEAN WELL's LED power supply	<p>Up to 4 channels</p>	<p>※Note: Only use Normally Open Push Button without light indicator .</p>	P
4	Dimming with LED PSU ON/OFF	*The DAP-04 is equipped with a relay that can be used to turn ON/OFF MEAN WELL LED PSUs. The relay is in the closed position when the DIM1 generates dimming signal; the relay is in the open position when there is no output signal on the DIM1.			P

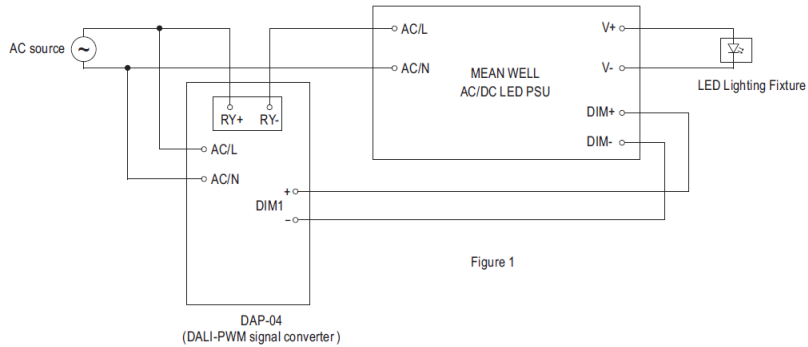

*An additional magnetic switch is needed when the total input current of the selected LED PSUs is higher than 8A or used with LED PSUs whose inrush current is greater than 50A, please refer to the figure 2.

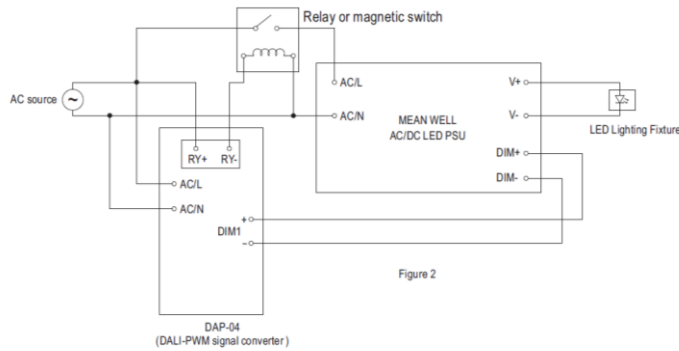

5 PUSH dim(primary side)

Function	Pushing time
No change of state	<0.05 sec.
Turn ON-OFF	0.1~1 sec.
Dimming up or down	1.5~10 sec.
Setting light to 100%	>11 sec.

_Maximum length of the cable, from push button to last driver, is 20 meter.

_Factory default dimming setting : 100%.

Every long pushing action will change the dimming direction

P

6 Description of DALI dimmer

a.OSRAM MCU dimmer: (OSRAM DALI model : DALI MCU)

dimming control	RESULT
RANGE : 1%~100%	OK

b. OSRAM BASIC (OSRAM DALI model : DALI RC BASIC SO)

dimming control	RESULT
Short press: turn off the luminaire	OK
Long press: dimming function, light intensity changes in every long presses	OK

P

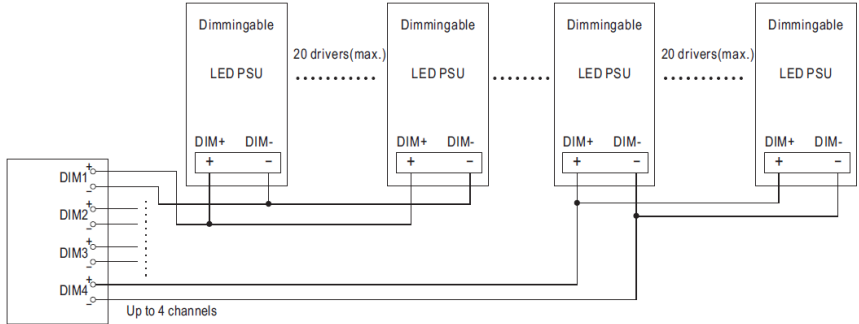
7	Combination of DALI and PUSHDIM	<table border="1"> <thead> <tr> <th data-bbox="466 286 699 318">function</th> <th data-bbox="699 286 1359 318">Description</th> </tr> </thead> <tbody> <tr> <td data-bbox="466 340 699 407">DALI signal priority</td> <td data-bbox="699 340 1359 407">Only DALI signal can be accepted be when there are DALI and PUSHDIM signals connected. Using ON/OFF the luminaire to do the verification.</td> </tr> <tr> <td data-bbox="466 421 699 474">Remove DALI signal</td> <td data-bbox="699 421 1359 474">Output will become full intensity automatically when DALI signal is removed and there is not action in pushdim.</td> </tr> </tbody> </table>	function	Description	DALI signal priority	Only DALI signal can be accepted be when there are DALI and PUSHDIM signals connected. Using ON/OFF the luminaire to do the verification.	Remove DALI signal	Output will become full intensity automatically when DALI signal is removed and there is not action in pushdim.	P
function	Description								
DALI signal priority	Only DALI signal can be accepted be when there are DALI and PUSHDIM signals connected. Using ON/OFF the luminaire to do the verification.								
Remove DALI signal	Output will become full intensity automatically when DALI signal is removed and there is not action in pushdim.								
8	SYNCHRONIZATION OPERATION	<p>*DAP-04 provides 4-channel outputs; every channel controls up to 20 units of MEAN WELL LED PSU.</p> <p>The 4 channels can thus control up to 80 units of MEAN WELL LED PSU. (Note. 1)</p> <p>*The dimming percentage of the MEAN WELL LED PSUs controlled by the same channel of DAP-04 is the same.</p> <p>The dimming percentage per DAP-04 channel can be controlled independently.</p> <p>*The maximum allowable voltage drop between the DAP-04 and LED PSUs should not be higher than 0.5V.</p>  <p style="text-align: center;">DAP-04 (DALI-PWM signal converter)</p> <p style="text-align: center;">Up to 4 channels</p>	P						

Note. 1 : Light intensity of LEDs in the same group may be decreased when one of the LED PSUs is AC OFF.

COMPONENT STRESS TEST

NO	TEST ITEM	SPECIFICATION	TEST CONDITION	RESULT	VERDICT
1	Diode Peak Voltage	D100 Rated 1A/200V	I/P : High-Line +3V = 308V O/P : (1)100% load (2)1% load (3)0% load Ta : 25°C	(1) 111 V (2) 111 V (3) 111 V	P
2	Input Capacitor Voltage	C5 Rated: 22u/450V	I/P : High-Line +3V = 308 V O/P : (1)100% load (2)1% load (3)0% load Ta : 25°C	(1) 438 V (2) 438 V (3) 439 V	P
3	Control IC Voltage Test	PWM IC U302 Rated 1.8V~3.6V	I/P : High-Line +3V = 308 V O/P : (1)100% load (2)1% load (3)0% load Ta : 25°C	(1) 3.4 V (2) 3.4 V (3) 3.4 V	P
4	Power Transistor Test	Q351 Rated : 300mA/60V	I/P : High-Line +3V = 308 V O/P : (1)100% load (2)1% load (3)0% load Ta : 25°C	(1) 10.8 V (2) 1 V (3) 0.5 V	P
5	TOP SWITCHING STAND BY POWER	U 1 Rated : 1040mA/700V	I/P : High-Line +3V = 308V O/P : (1)100% load (2)1% load (3)0% load Ta : 25°C	(1) 576 V (2) 576 V (3) 576 V	P

■ SAFETY & E.M.C. TEST

SAFETY TEST

NO	TEST ITEM	SPECIFICATION	TEST CONDITION	RESULT	VERDICT
1	WITHSTAND VOLTAGE	EN 60950 I/P-O/P: 3.75KVAC/min	I/P-O/P: 4 KVAC/min Ta:25°C	I/P-O/P: 1.42 mA NO DAMAGE	P
2	ISOLATION RESISTANCE	I/P-O/P:500VDC>100MΩ	I/P-O/P: 500 VDC Ta:25°C	I/P-O/P: 26 GΩ NO DAMAGE	P

E.M.C TEST

NO	TEST ITEM	SPECIFICATION	TEST CONDITION	RESULT	VERDICT
1	HARMONIC	EN61000-3-2 CLASS C	I/P:240VAC/230VAC/220VAC/60HZ O/P:100%LOAD Ta:25°C	PASS	P
2	CONDUCTION	EN55015 CLASS B	I/P:230 VAC (50HZ) O/P:FULL/50% LOAD Ta:25°C	PASS	P
3	RADIATION	EN55015 CLASS B	I/P: 230 VAC (50HZ) O/P:FULL LOAD Ta:25°C	PASS Test by certified Lab	P
4	E.S.D	EN61000-4-2 INDUSTRY AIR:8KV / Contact:4KV	I/P: 230 VAC/50HZ O/P:FULL LOAD Ta:25°C (AIR:8.8KV / Contact:4.4KV)	CRITERIA A	P
5	E.F.T	EN61000-4-4 INDUSTRY INPUT: 2KV	I/P: 230VAC/50HZ O/P:FULL LOAD Ta:25°C (INPUT: 2.2KV)	CRITERIA A	P
6	SURGE	IEC61000-4-5 INDUSTRY L-N :2KV L,N-PE:4KV	I/P: 230VAC/50HZ O/P:FULL LOAD Ta:25°C (L-N:2.2kV)	CRITERIA A	P

RELIABILITY TEST

ENVIRONMENT TEST

NO	TEST ITEM	SPECIFICATION	TEST CONDITION	RESULT	VERDICT																																																												
1	TEMPERATURE RISE TEST	MODEL : DAP-04 1. ROOM AMBIENT BURN-IN : 13 HRS I/P : 230VAC O/P : FULL LOAD Ta= 29.7 °C 2. HIGH AMBIENT BURN-IN : 5.5 HRS I/P : 230VAC O/P : FULL LOAD Ta= 61.8 °C	<table border="1"> <thead> <tr> <th>NO</th> <th>Position</th> <th>ROOM AMBIENT Ta= 29.7 °C</th> <th>HIGH AMBIENT Ta= 61.8 °C</th> </tr> </thead> <tbody> <tr><td>1</td><td>BD1</td><td>37.7°C</td><td>70.1°C</td></tr> <tr><td>2</td><td>C5</td><td>38.5°C</td><td>70.7°C</td></tr> <tr><td>3</td><td>D1</td><td>39.6°C</td><td>73.6°C</td></tr> <tr><td>4</td><td>U1</td><td>42.8°C</td><td>75.9°C</td></tr> <tr><td>5</td><td>TI COIL</td><td>35.3°C</td><td>68.1°C</td></tr> <tr><td>6</td><td>D100</td><td>35.8°C</td><td>69.9°C</td></tr> <tr><td>7</td><td>C101</td><td>34.7°C</td><td>68.0°C</td></tr> <tr><td>8</td><td>U100</td><td>35.9°C</td><td>70.9°C</td></tr> <tr><td>9</td><td>Q150</td><td>37.0°C</td><td>71.2°C</td></tr> <tr><td>10</td><td>BD30</td><td>38.4°C</td><td>70.7°C</td></tr> <tr><td>11</td><td>U3</td><td>37.9°C</td><td>70.0°C</td></tr> <tr><td>12</td><td>U302</td><td>35.5°C</td><td>70.4°C</td></tr> <tr><td>13</td><td>Q351</td><td>34.2°C</td><td>68.9°C</td></tr> <tr><td>14</td><td>ZD35</td><td>32.8°C</td><td>67.4°C</td></tr> </tbody> </table>	NO	Position	ROOM AMBIENT Ta= 29.7 °C	HIGH AMBIENT Ta= 61.8 °C	1	BD1	37.7°C	70.1°C	2	C5	38.5°C	70.7°C	3	D1	39.6°C	73.6°C	4	U1	42.8°C	75.9°C	5	TI COIL	35.3°C	68.1°C	6	D100	35.8°C	69.9°C	7	C101	34.7°C	68.0°C	8	U100	35.9°C	70.9°C	9	Q150	37.0°C	71.2°C	10	BD30	38.4°C	70.7°C	11	U3	37.9°C	70.0°C	12	U302	35.5°C	70.4°C	13	Q351	34.2°C	68.9°C	14	ZD35	32.8°C	67.4°C		P
NO	Position	ROOM AMBIENT Ta= 29.7 °C	HIGH AMBIENT Ta= 61.8 °C																																																														
1	BD1	37.7°C	70.1°C																																																														
2	C5	38.5°C	70.7°C																																																														
3	D1	39.6°C	73.6°C																																																														
4	U1	42.8°C	75.9°C																																																														
5	TI COIL	35.3°C	68.1°C																																																														
6	D100	35.8°C	69.9°C																																																														
7	C101	34.7°C	68.0°C																																																														
8	U100	35.9°C	70.9°C																																																														
9	Q150	37.0°C	71.2°C																																																														
10	BD30	38.4°C	70.7°C																																																														
11	U3	37.9°C	70.0°C																																																														
12	U302	35.5°C	70.4°C																																																														
13	Q351	34.2°C	68.9°C																																																														
14	ZD35	32.8°C	67.4°C																																																														
3	LOW TEMPERATURE TURN ON TEST	TURN ON AFTER 2 HOUR	I/P : 305VAC/100VAC O/P : 100 % LOAD Ta= -35 °C	TEST : OK	P																																																												
4	HIGH HUMIDITY HIGH TEMPERATURE HIGH VOLTAGE TURN ON TEST	AFTER 12 HOURS IN CHAMBER ON CONTROL 60 °C NO DAMAGE	I/P : 308 VAC O/P : FULL LOAD Ta= 60 °C HUMIDITY= 95 %R.H	TEST : OK	P																																																												
6	STORAGE TEMPERATURE TEST	1. Thermal shock Temperature : -45°C~ +90°C 2. Temperature change rate : 25°C / MIN 3. Dwell time low and high temperature : 30 MIN/EACH 4. Total test cycle : 5 CYCLE 5. Input/Output condition : STATIC		OK	P																																																												
7	THERMAL SHOCK TEST	1. Thermal shock Temperature : -35°C~ +65°C 2. Temperature change rate : 25°C / MIN 3. Dwell time low and high temperature : 30 MIN/EACH 4. Total test cycle : 10 CYCLE 5. Input/Output condition : 230VAC/Full Load AC ON/OFF TEST turn on 58sec ; turn off 2sec		OK	P																																																												
8	VIBRATION TEST	1 Carton & 1 Set (1) Waveform : Sine Wave (2) Frequency : 10~500Hz (3) Sweep Time : 12min/sweep cycle (4) Acceleration : 2G (5) Test Time : 60min in each axis (X.Y.Z) (6) Ta : 25°C		TEST : OK	P																																																												



DALI-PWM Signal Converter

DAP-04 series

9	CAPACITOR LIFE CYCLE	SUPPOSE C101 IS THE MOST CRITICAL COMPONENT (1) I/P : 230VAC O/P : FULL LOAD Ta= 25 °C LIFE TIME (2) I/P : 230VAC O/P : FULL LOAD Ta= 60 °C LIFE TIME	(1) 1086115 HRS (2) 88320 HRS	P
10	MTBF	MIL-HDBK-217F NOTICE S2 PARTS COUNT TOTAL FAILURE RATE : 246.9 KHRS		P
11	DMTBF/Accelerated Life Test	Demonstration Mean Time Between Failure(Expected Life) : 30,000 hours @ Tcase 75 °C		P

TEST RESULT	TESTER	REVIEW	APPROVAL
PASS	DANIEL GAO	SANFORD SU	VINCENT TSENG

12.10.30 A50-F031